

**Montageanleitung**  
**Instructions de montage**  
**Istruzioni di montaggio**

DE  
FR  
IT

**Gerätetruhe Metall**  
**Coffre en métal**  
**Scatola di metallo**



**Art. Nr. 24466.01**  
**106298**

**Geräteübersicht**  
**Description de l'appareil**  
**Descrizione dell'apparecchio**



Abmessung (LxTxH) Dimensions (LxTxH) Dimensioni (LxPxA) **ca. x 132 x 61 x 62cm**

**Teileübersicht**  
**Aperçu des pièces**  
**Panoramica delle parti**

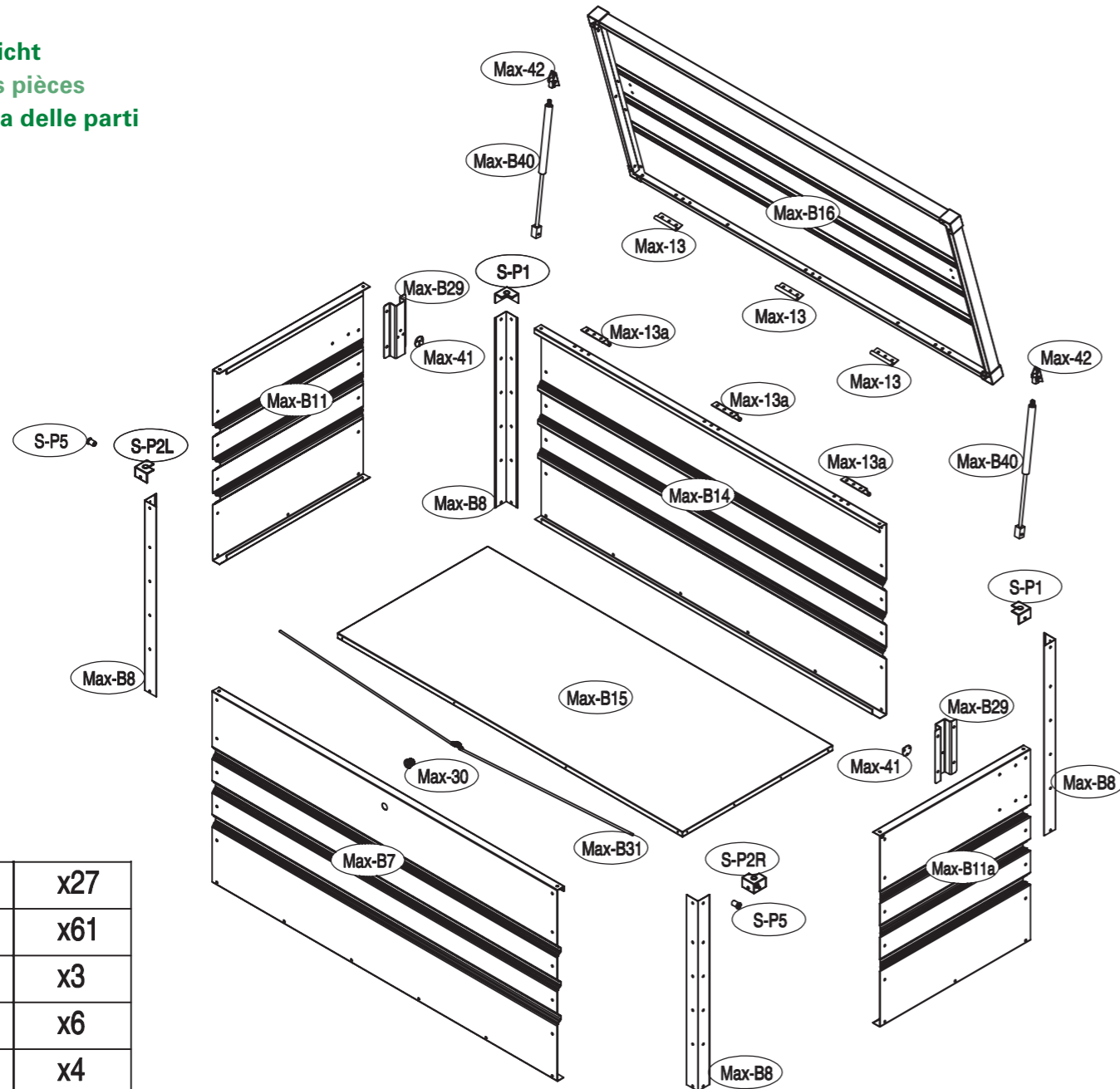

Max-B51	x27
Max-B52	x61
Max-B53	x3
Max-B55	x6
Max-B56	x4

**Montageanleitung**  
**Instructions de montage**  
**Istruzioni per l'assemblaggio**

- ! Vor Erstgebrauch vollständig auspacken, Verpackungsmaterial entfernen und Montageanleitung lesen.  
 Avant la première utilisation, déballer complètement, retirer le matériel d'emballage et lire les instructions de montage.
- Spacchettare completamente prima del primo utilizzo, eliminare il materiale da imballaggio e leggere le istruzioni di montaggio.

**1**

I & II

**2**

Max-B51: x4

**3**

Max-B51: x3 / Max-B52: x8

**4**

Max-B51: x2 / Max-B52: x8

**5**

Max-B51: x3 / Max-B52: x8

5

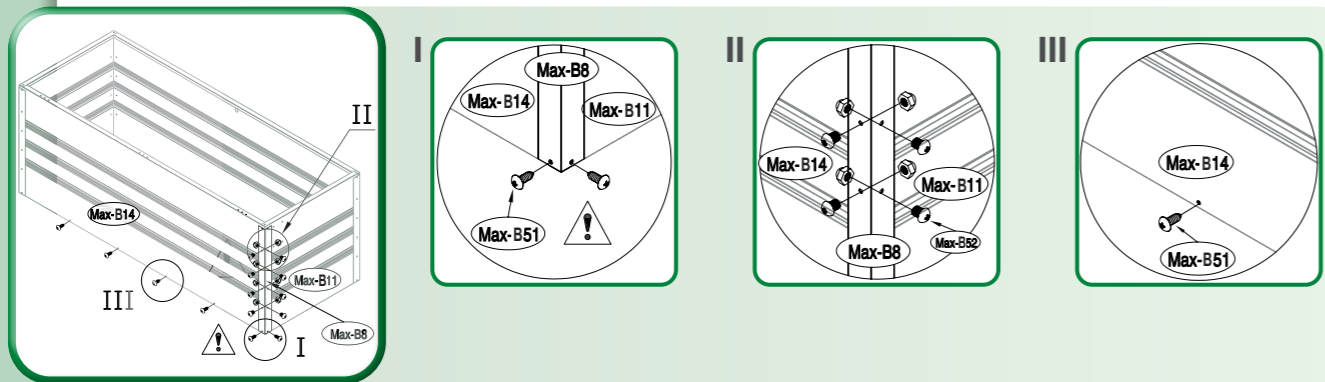

Max-B51: x6 / Max-B52: x8

6

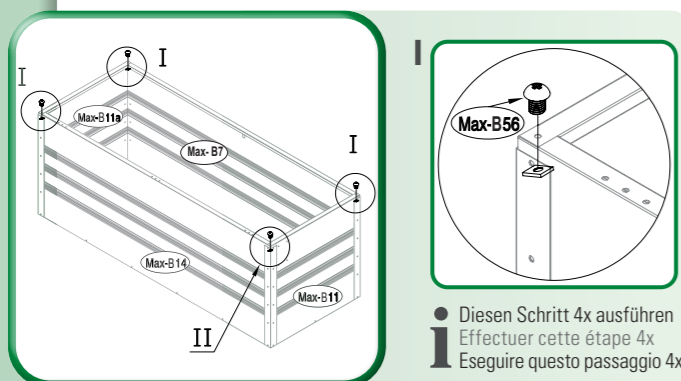

Diesen Schritt 4x ausführen  
Effectuer cette étape 4x  
Eseguire questo passaggio 4x

Max-B56: x4

7

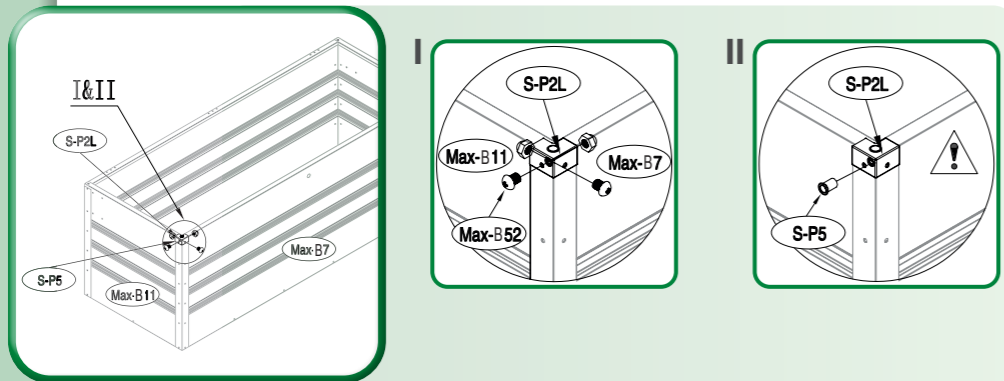

S-P2L: x1 / S-P5 x1 / Max-B52: x2

8

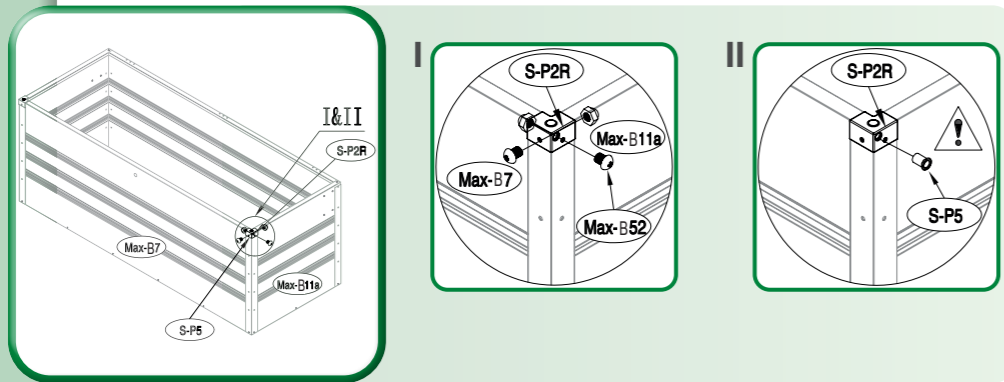

S-P2R: x1 / S-P5 x1 / Max-B52: x2

9

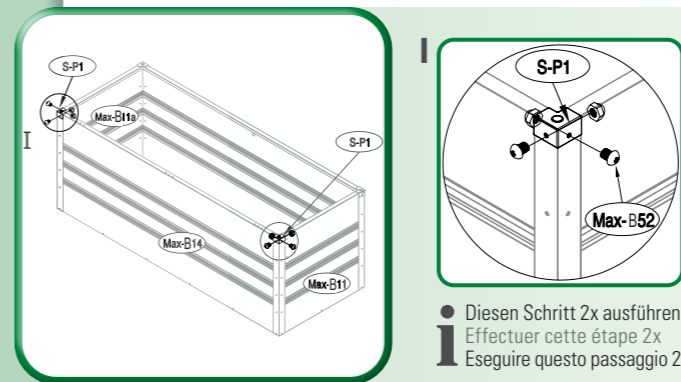

Diesen Schritt 2x ausführen  
Effectuer cette étape 2x  
Eseguire questo passaggio 2x

S-P1: x2 / Max-B52: x4

10

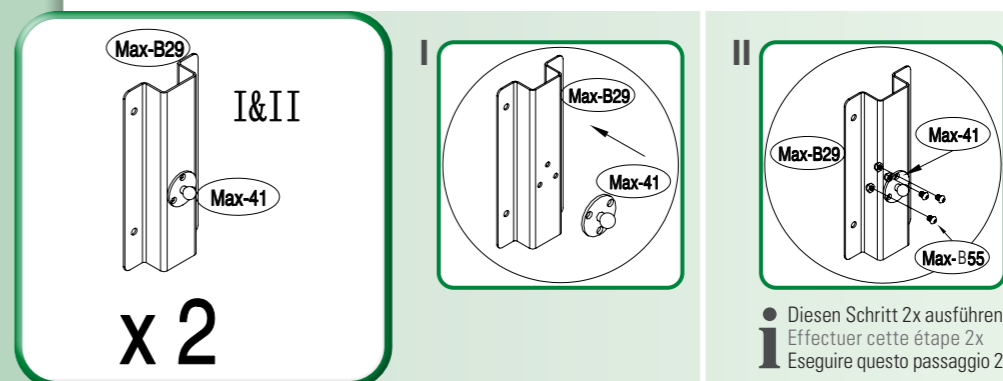

Diesen Schritt 2x ausführen  
Effectuer cette étape 2x  
Eseguire questo passaggio 2x

Max-41: x2 / Max-B55: x6

11

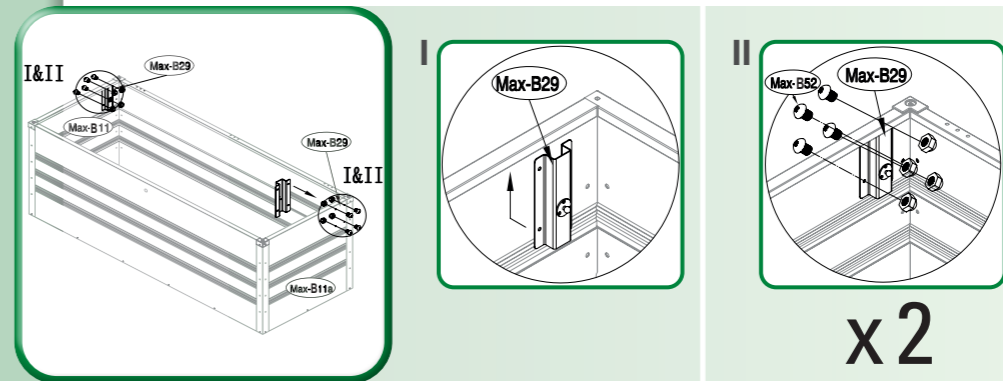

Max-B52: x6

12

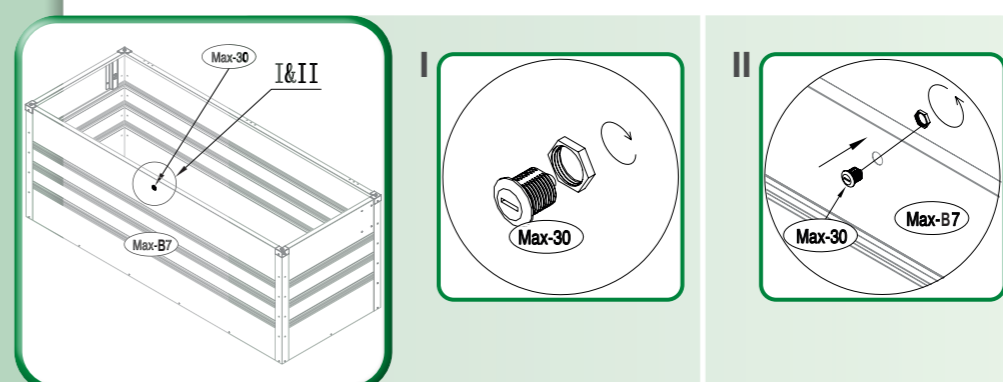

Max-30: x1

13

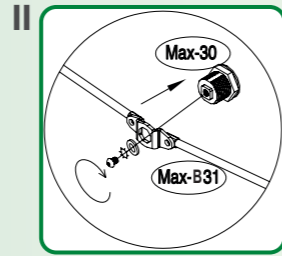
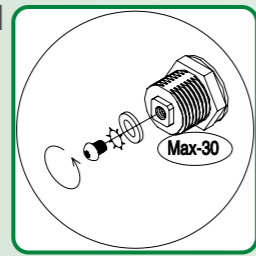
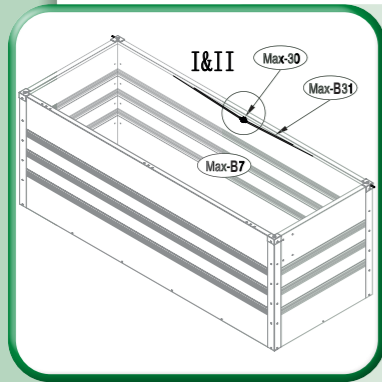

14

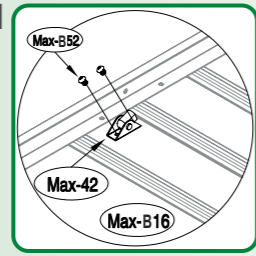
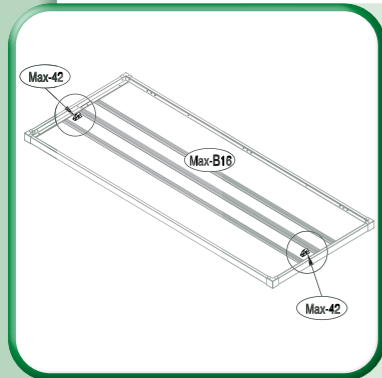

Diesen Schritt 2x ausführen  
Effectuer cette étape 2x  
Eseguire questo passaggio 2x

Max-42: x2 / Max-B52: x4

15

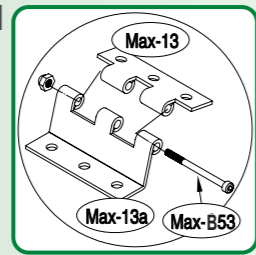
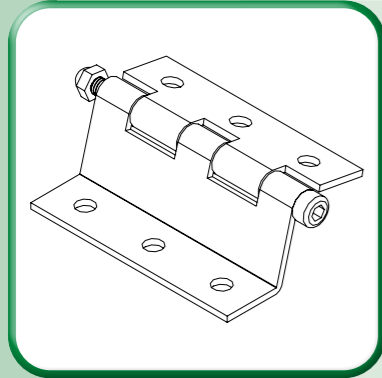

Diesen Schritt 3x ausführen  
Effectuer cette étape 3x  
Eseguire questo passaggio 3x

Max-13: x3 / Max-13: x3 / Max-B53: x3

16

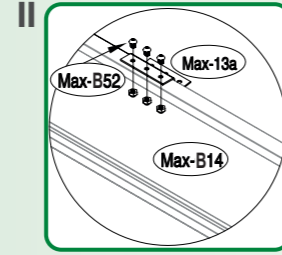
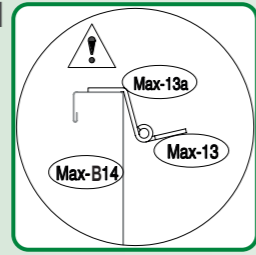
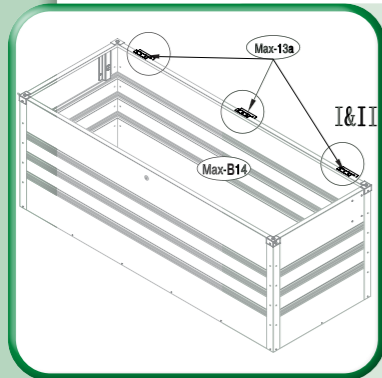

x3

17

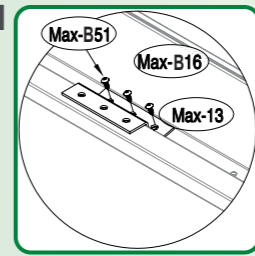
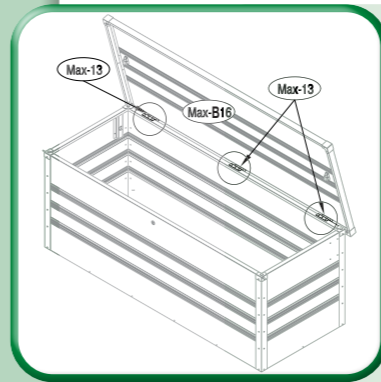

Diesen Schritt 3x ausführen  
Effectuer cette étape 3x  
Eseguire questo passaggio 3x

Max-B51: x9

18

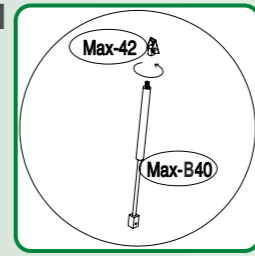
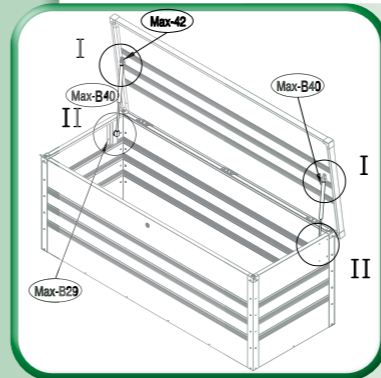

Diesen Schritt 2x ausführen  
Effectuer cette étape 2x  
Eseguire questo passaggio 2x

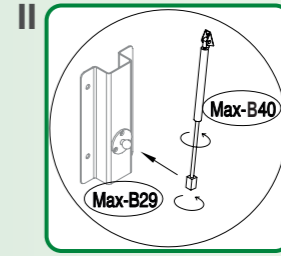

Diesen Schritt 2x ausführen  
Effectuer cette étape 2x  
Eseguire questo passaggio 2x

Max-B40: x2

19



Gerätetruhe im Garten installieren  
Installer un coffre à outils dans le jardin  
Installazione di una cassetta degli attrezzi in giardino

## **5 Jahre Garantie für Gerät**

## **5 ans garantie sur l'appareil**

## **5 anni garanzia per l'apparecchio**

Die Garantie beginnt mit dem Kauf eines Artikels und endet entsprechend dem Datums-Andruck auf dem Kassenbeleg nach 5 Jahren. Dieser Garantieanspruch wird auch dann beibehalten, wenn ein Gerät in diesem Zeitraum durch ein Neues ersetzt wurde. Ausgenommen Verschleissteile.

La garantie prend effet le jour de l'achat d'un article et expire 5 ans après la date imprimée sur le ticket de caisse. Si un appareil est remplacé par un neuf durant ce délai, vous conservez votre droit de garantie. Les pièces d'usure ne sont pas couvertes par la garantie.

La garanzia decorre dall'acquisto di un articolo e decade dopo 5 anni dalla data stampata sullo scontrino. Il diritto alla garanzia viene mantenuto anche se, in questo stesso periodo, un apparecchio è stato sostituito con uno nuovo. Eccetto le parti usurate.

**Vertrieb**  
**Distribution**  
**Distribuzione**

LANDI Schweiz AG  
Schulriederstrasse 5  
CH-3293 Dotzigen  
[www.landi.ch](http://www.landi.ch)